

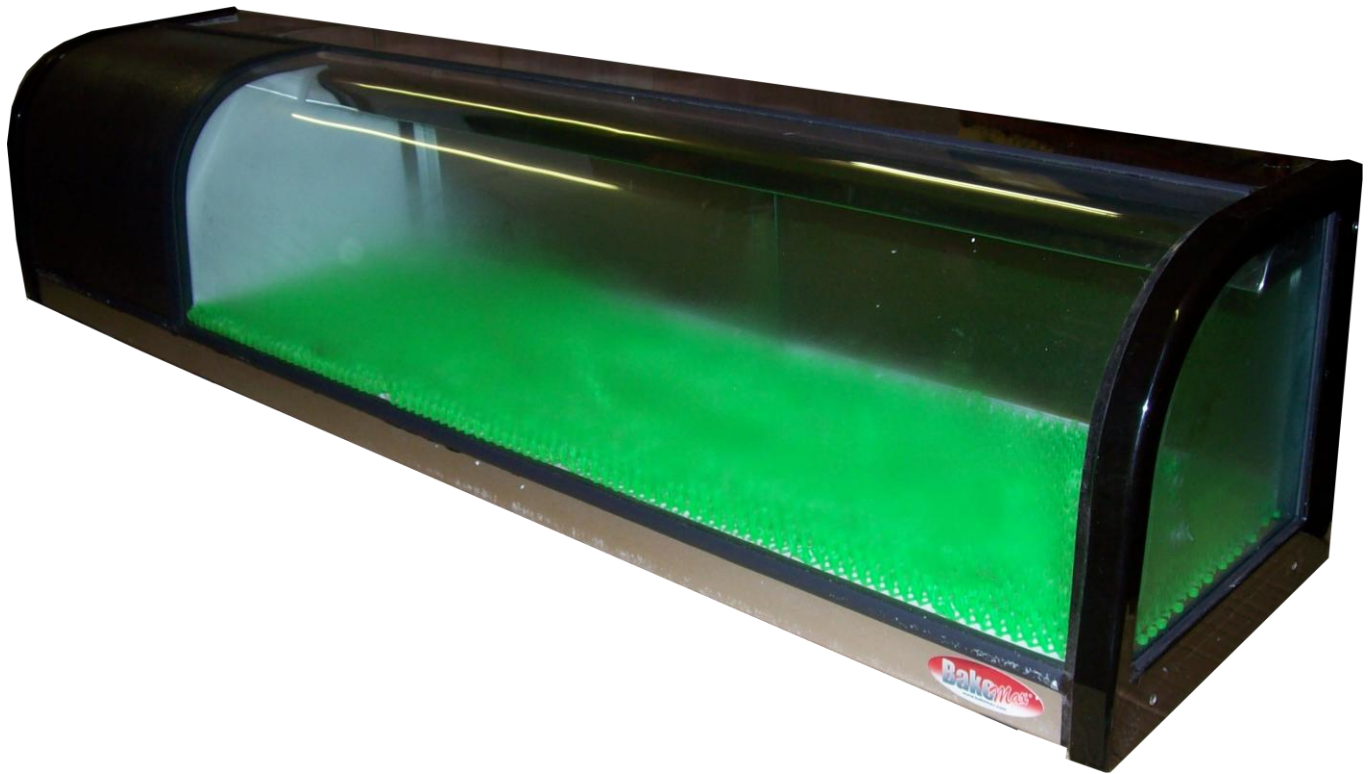

SUSHI SHOWCASE

BMCSS05





WARNING: PLEASE READ AND FOLLOW THE INSTRUCTIONS BELOW BEFORE OPERATING PRODUCT

- When using the machine, please confirm that you have read all the instructions within this manual.
- Beware of any child/children or any other persons who are near the machine before operating.
- Do not put hand near moving parts.
- Remove all obstacles, which may interfere with machine functions.
- Keep work area clean and clear of clutter.
- Do not sit or stand on machine
- Do not wear loose cloth or jewellery when operating machine as it may get caught in moving parts and cause injury
- When the machine is abnormal or broken, you should stop using and check it or have it checked by a professional.
- Disconnect from power source before performing maintenance on the machine.
- When machine is not in use, please clean and store properly.
- Do not place any electrical parts or plug/cord in water.
- The cord should be away from the heat.
- Don't hang out the cord on the desk or cabinet.
- Machine may have sharp or pointed edges, use caution when cleaning.
- This machine should only be operated by personnel who can read, understand and respect warnings and instructions regarding this machine and the manual.
- Keep this manual in a safe place for further and regular reference and ordering parts.
- Please write model serial and date of purchase of your machine in the space provided in case you will need to order parts in the future.
- Always work by security code of your country, state, province, city or committee of your work place.

Showcase Specific Warnings.

The following warnings refer to all BakeMax® Heated Showcases.

- Keep the surrounding of the show case clean of clutters and papers to avoid fire
- Keep all heated show cases on a non combustibile surface
- Keep all heated showcases out of reach of small children
- Always turn off thermostat at night or when show case is not in use
- Always allow time to cool down before cleaning or perform maintenance on showcase

Thank you for your choice of sushi showcase. Please read through this USERS MANUAL before operating your machine.

- **OUTLINE OF THE PRODUCTS**

- This series of sushi showcase has been equipped with a highly efficient hermetic compressor with high power condensing and low energy consumption.
- This series of sushi showcase uses arc/curved shaped glass to make the food inside more visible, with semi-transparent glass at both sides.
- The showcase can be used as a refrigerated cake unit or other similar food.
- With foaming by environment friendly polyurethane, the sushi showcase has a durable and attractive appearance.

- **MAIN TECHNICAL DATA**

| | |
|---------------------------------|--------------|
| Model | BMCSS05 |
| Capacity(L) | 91 |
| Total power input(W) | 350 |
| Voltage | 110 |
| (E) | 10±3 |
| Refrigerant name | R22/R134a |
| N.W.(Kg) | 41 |
| Climate type | N |
| Electric-shock protection class | I |
| Dimension(mm) | 1500X350X340 |

• OVERALL DIAGRAM

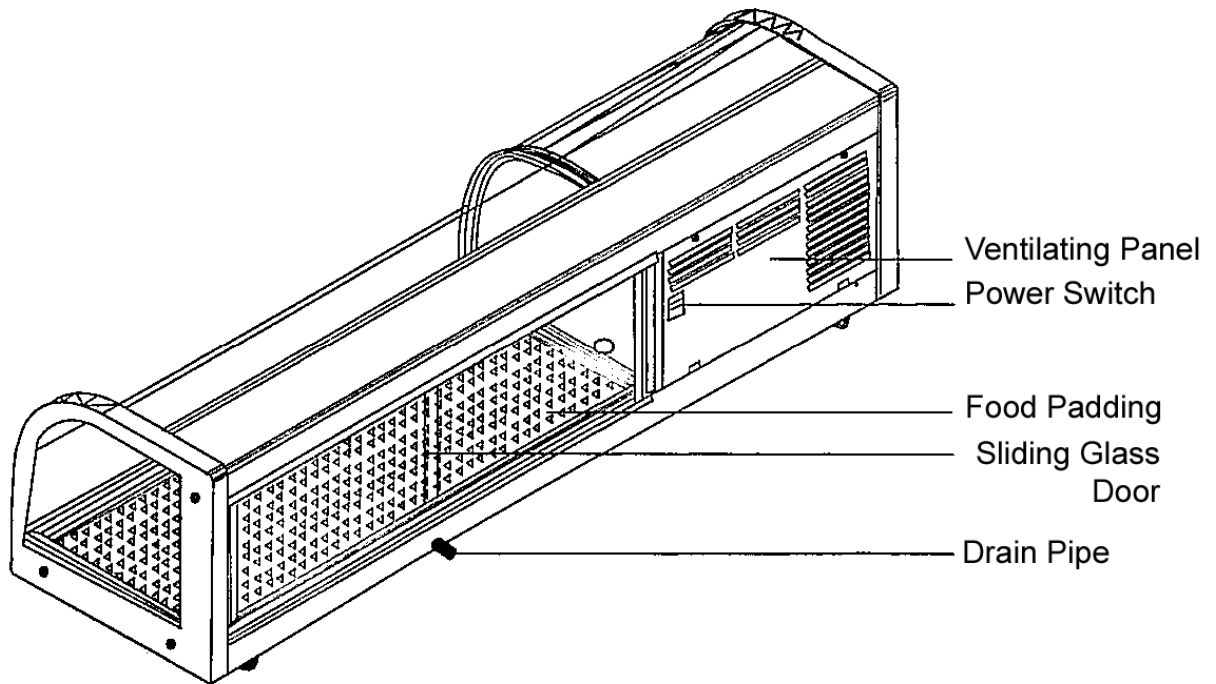
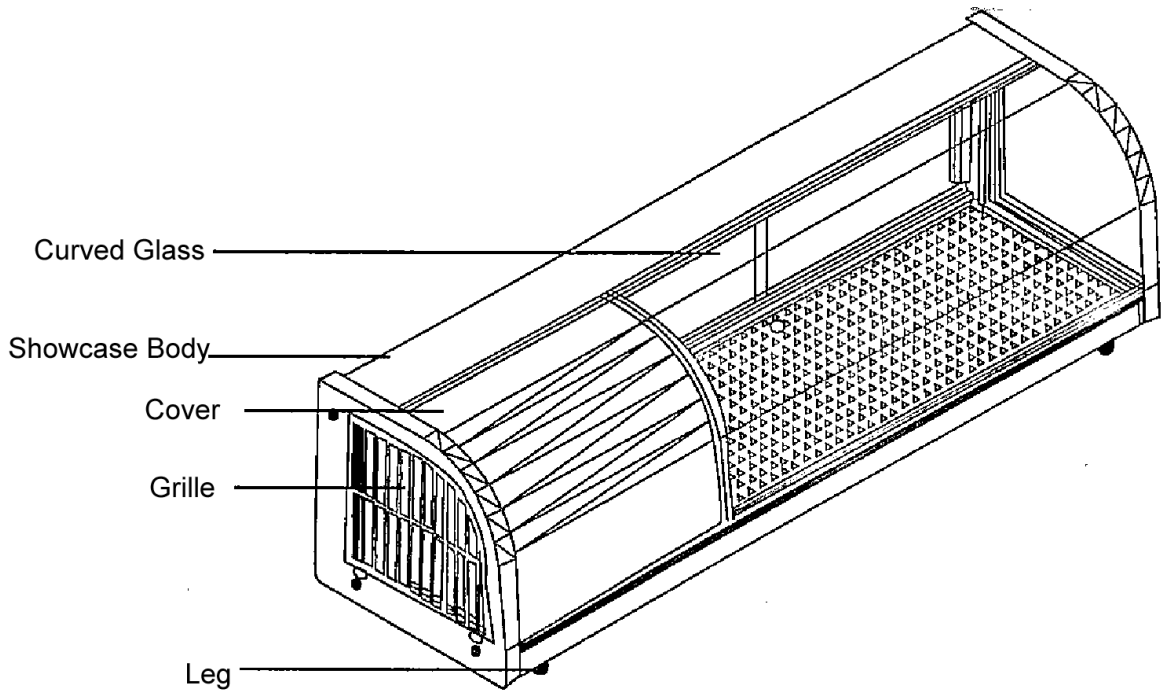

• CAUTIONS FOR SAFETY

- Use a specific socket when operating the showcase to prevent overheating a result of multiple applications on a single socket.

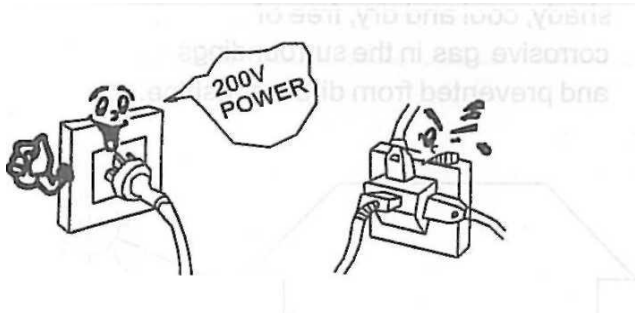

- Don't pour water on or in the machine, or it may cause electricity leakage or damage.

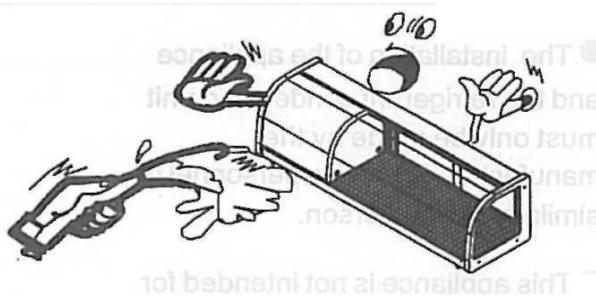

- Never use fuel gas near the machine or keep corrosive products inside the showcase, such as alcohol, butane etc.

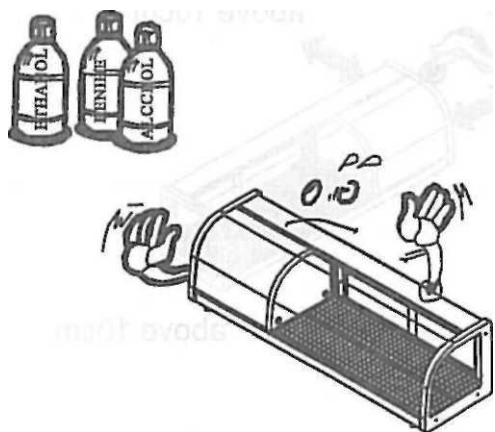

- Please unplug the machine and ask for a trained technician to check the machine once foreign taste, smoke or high temperature to be found in the showcase.

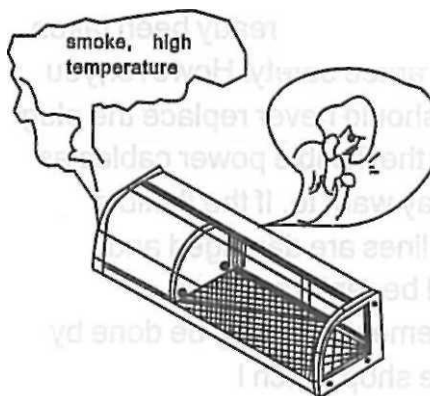

- Before removing the machine, pull out the power plug. Never turn the machine up side down or lay it on its side. If it has to be inclined, the tilt angle should not exceed 30°
- The sushi showcase must be grounded and the earth wire is not allowed to connect with water pipe or gas pipe.
- The installation of the appliance and the refrigerant condensing unit must only be made by the manufacturer's service personnel or similarly skilled person.
- This appliance is not intended for use by persons(including children) with reduced physical,sensory or mental capabilities, or lack of experience and knowledge, unless they have been given supervision or instruction concerning use of the appliance by a person responsible for their safety.
- Children should be supervised to ensure that they do not play with the appliance.
- This product is classified as category I shock-prevention electric appliance that perfect measures have already been taken to guarantee safety. However.you users should never replace the plug and/or the flexible power cables as you may want to. If the flexible power lines are damaged and should be replaced.their replacement may only be done by service shop which have been authorized by our company.

● HOW TO OPERATE

- Application environment: Ambient temperature[^]26°C, RH[^]65%

- The sushi showcase should be placed in an environment where is shady, cool and dry, free of corrosive gas in the surroundings and prevented from direct sunshine.
- The sushi showcase must keep a clearance of about 10cm at its right, left, and rear sides, respectively, so as

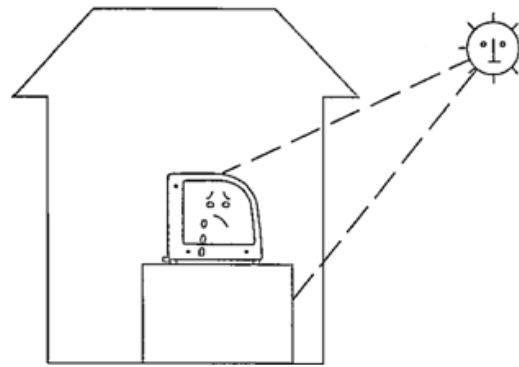

to ensure an adequate airflow and efficient operation of the machine.

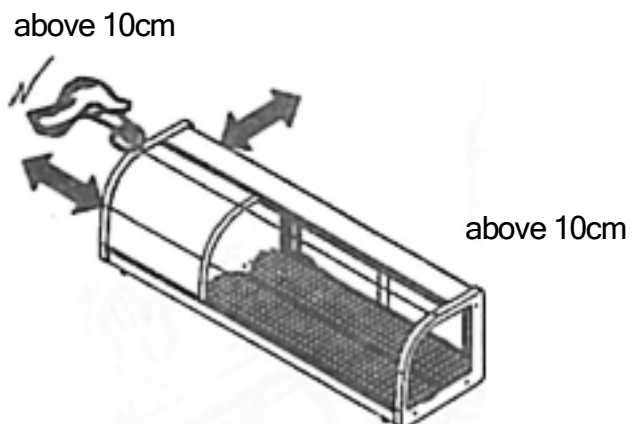

- Don't put the sushi showcase tipsily.

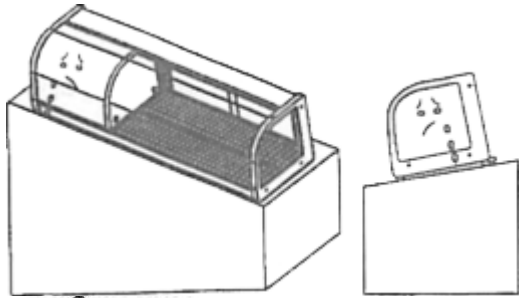

- For the first time of operation the machine, you must let the machine running at least for an hour without any food inside the sushi showcase before you put the food into the showcase. Some space should be remained between the food displayed, so as to allow a certain airflow and assure even temperature in the showcase.

- It must have 5-minute-break before you restarting the machine.

- Don't hang the sushi showcase in the air.

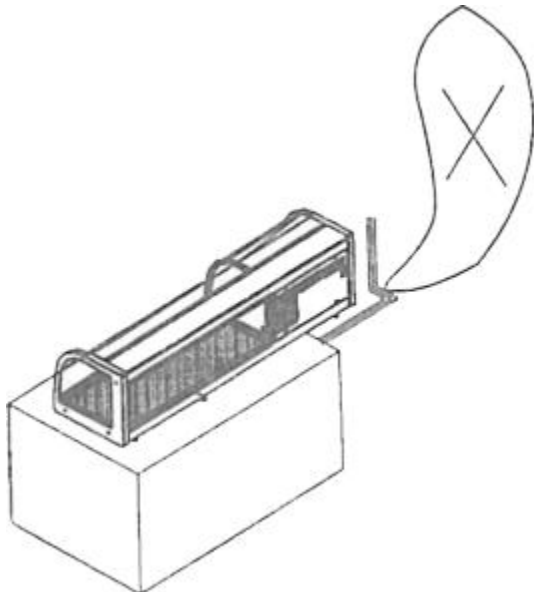

- Don't touch the refrigerating parts when the machine is working or it will hurt your hands.

- Don't open the door of the showcase frequently or let its door open for a long time, it will results high electricity consumption and the working efficiency of the machine.

- Please wrap up the strong smelt food with a non poisonous bag when putting the food into the showcase.

- Please take the food out of the showcase and drain its defrosting water out when the showcase cooler is out of service.

SERVICE AND MAINTENANCE

- Please pull out the plug ,take the food out of the showcase and clean the showcase with a soft cloth and soft soap water. When the machine is intended to be out of service for a long time. Observe the condenser frequently through the shuttle. Much dirt or dust restricts the airflow and low the rediation

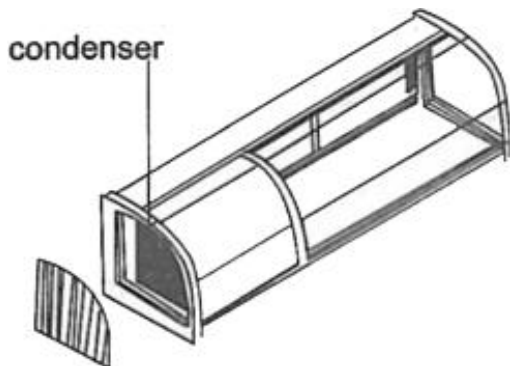

effect. You ate recommended to clean the dirt and dust on the condenser by compressed air or tap water every three months.

When washing the condenser with running water, a piece of piastic film should be used to wrap up and protect both the electric units and the connections before a water-flushing is carried out. Only when the freeing system is air-dried can the power switch be turned on.

• WORKING PRINCIPLE DIAGRAM

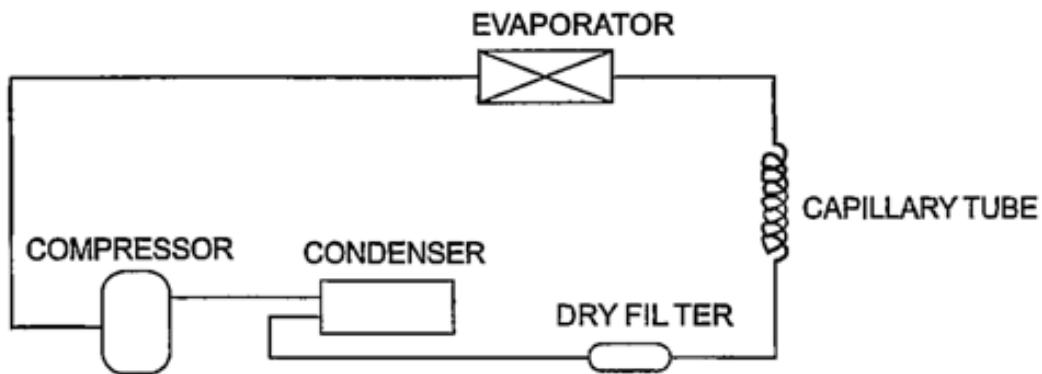

• ELECTRIC PRINCIPLE DIAGRAM

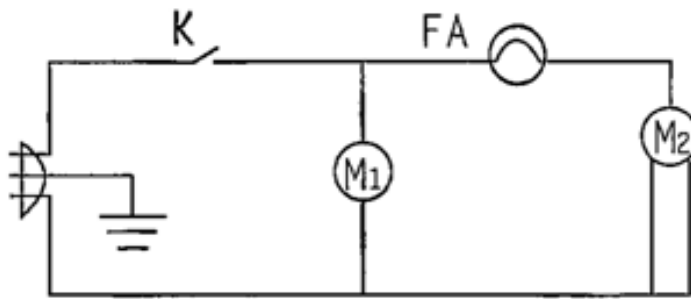

K SWITCH
M1 FAN MOTOR
M2 COMPRESSOR
FA OVERLOAD PROTECTOR

• **COMMON TROUBLES AND TROUBLE SHOOTING**

| Case | Possible cause | What to check | Remedy | Remarks |
|----------------------------|--|-----------------------------------|--|------------------------------------|
| No power input | Broken fuse | Check the fuse | Replace the fuse | Repair by an electrician as needed |
| | Poor contact of plug with socket | Any plug loosening with socket | Repair or replace the socket | |
| High temp. inside showcase | The machine is near heat source | Check for surroundings | Move away the heat source from the machine | |
| | Too thick ice building on the evaporator | | Defrost in time or shorten the defrost cycle | |
| | Too much food inside the showcase | Check for airflow | Take out some food | |
| | Refrigerant leakage | | Check at the repairing shop | |
| High noise level | The machine is not level | Check for legs landed or not | Land the machine firmly | |
| | Loose screws of the condenser bracket or compressor base | Check for screws fastening | Fasten the screws | |
| compressor does not work | Loose plug pins in starter or thermal relay | Check for broken pins in the plug | Insert the plug tight | Repair by authorized technicians |
| | Broken compressor | | Repair or replace the compressor | |
| | Voltage beneath 187V or beyond 242V | Check voltage in power supply | Connect to a voltage regulator 5 times the total power input | |

CASES AS FOLLOWS ARE NOT TROUBLE

- There is a running water sound in the freezing pipe circuit: This running water sound is a normal sound created by the refrigerant while flowing.
- There is a heat at the surface while the compressor operating: When the compressor operates normally, temp. at the surface will be rather high that never touch it with your hand though it is of a normal status.

NOTES:

- If the technical parameters are changed, the parameters are accurate in accordance with the nameplate on the sushi showcase.
- If the product design is changed in the future, please excuse us not inform the customer alone.

STRUCTURE

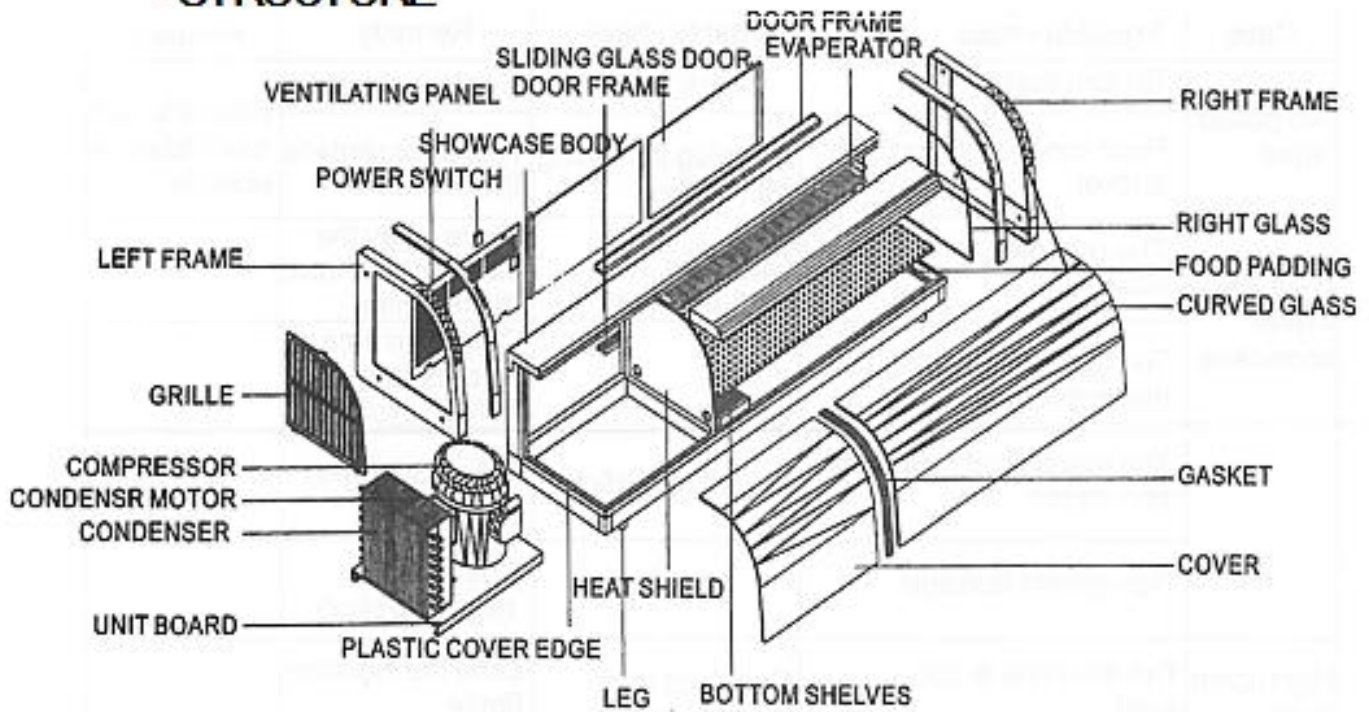

• STRUCTURE DIAGRAM(DOUBLECOMPARTMENTS)

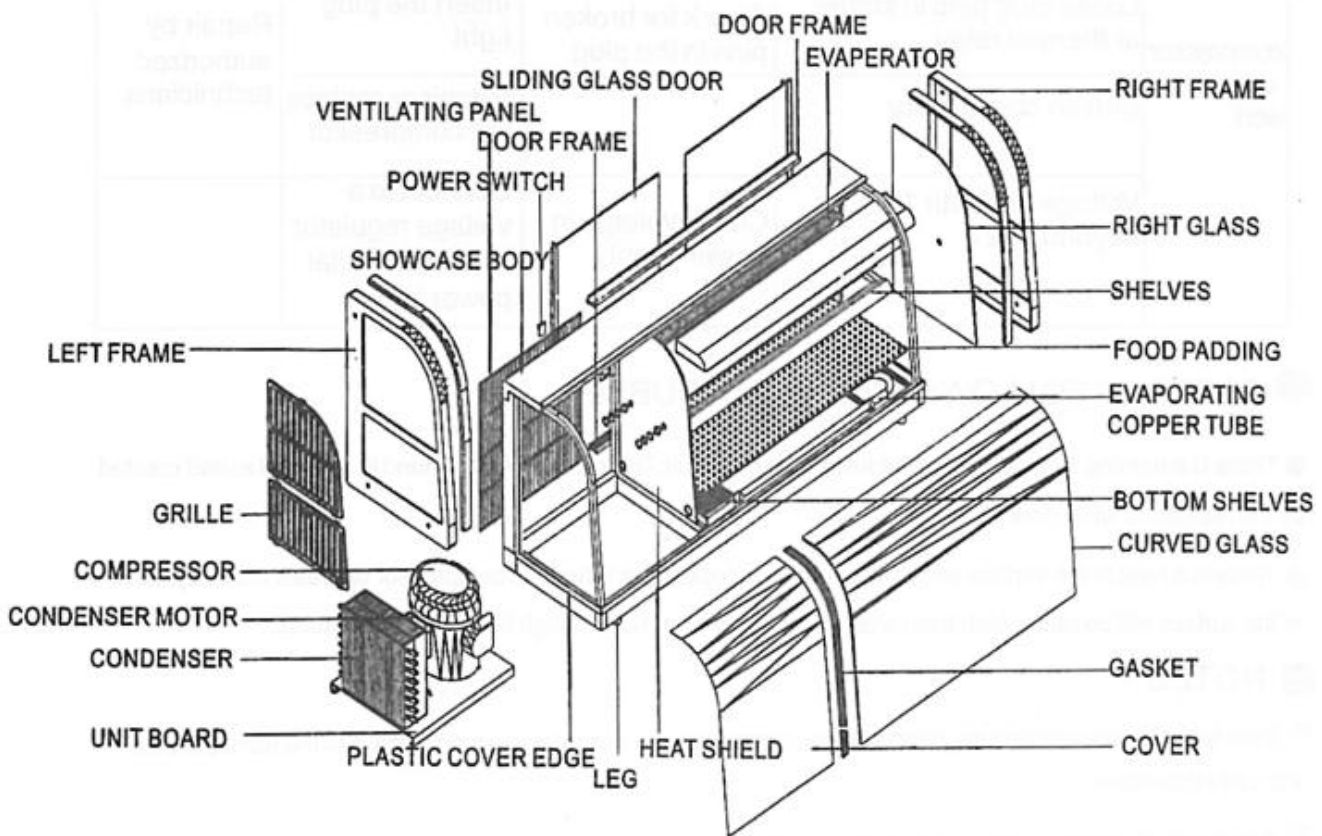

Warranty



- One year Parts and Labor limited warranty.
- Warranty begins at date of installation, delays of installation and extended warranty must be approved.
- All equipment must be properly installed and connected by qualified professionals if not a standard Plug 'N Go* operation.
- All equipment must be used within tolerance limits of machine.
- Any abuse of equipment or improper use of machine will void the warranty.
- Accessories or attachments have 90 day warranty to be repaired or replaced.
- Repairs include Parts and Labor only, excluded are the following:
 - Electrical components such as fuses, bulbs, elements switches are not covered by this warranty.
 - Overtime labor rates.
 - Expedited freight for parts.
 - Travel charges.
- All defective parts must be returned to BakeMax® for credit.
- BakeMax® is not responsible for production downtime or product losses.
- Repairs must be pre-authorized by BakeMax® prior to work commencing.
- Emergency service 24/7 at 1-800-565-2253

SPECIAL TERMS & CONDITIONS

- BakeMax® reserves the right to make improvements or equipment specification changes without prior notice.
- Set up and installation is client's responsibility.
- Failure to follow all instructions in operations manual, properly install, maintain equipment, follow capacity charts, or electrical information may void warranty.

Titan Ventures International Inc.
PO Box 23083, Moncton NB, E1A 6S8
Toll Free: 1-800-565-BAKE
Telephone: 1-506-858-8990
Fax: 1-506-859-6929

*Plug 'N Go operation requires machine be properly connected to proper wall outlet.

Think Quality, Value, Service.....Think

BakeMax®

Printed in Canada

Toll Free: 1-800-565-BAKE Web Site: www.bakemax.com E-mail: sales@bakemax.com