



Item No. _____

30qt PLANETARY MIXER BMPM030

Features:

- Gear driven.
- Professional table top model.
- 1 HP motor offers enough power to mix stiffer dough and larger batches.
- All metal and die-cast aluminum body.
- Transmission is made of hardened alloy steel gears.
- All shafts are mounted in ball bearings.
- Automatic electronic 3 speed control.
- Planetary mixing action ensures perfect results.
- Simple hand lift for tool change and bowl removal.
- Easy speed shifting.

Other specifications:

- 30qt stainless steel bowl.
- # 12 Hub
- Includes dough hook, flat beater and wire whip.
- Safety guard is standard for model BMPM030 and provides with automatic shut-off when guard is opened at any speed.
- NEMA: L5-15P.



BakeMax[®] Planetary Mixers provide durability, long life and excellent mixing performance. A wide range of sizes to choose from provides clients with the exact mixer for their particular needs. They are safe, easy to use and capable of a broad range of dough and food mixing applications.



Think Quality, Value, Service.....Think



30qt PLANETARY MIXER BMPM030

Volume

External and Internal Dimensions (D x W x H)

Model	External
BMPM030	22.5" x 22.6" x 44"

Capacity Chart (approx.) 30 Quart

Product	Tool	Amount
Egg White	Whip	1.5 qt
Whipping Cream	Whip	6 qts
Mayonnaise (oil)	Whip	12 qts
Layer cake (egg/sugar)	Beater	30 lbs
Mashed Potatoes	Beater	20 lbs
Pound Cake	Beater	23 lbs
Bread Dough (Light)	Hook*	15 lbs (Flour)
Bread Dough (Heavy)	Hook*	12 lbs Flour
Whole Wheat Dough	Hook**	15 lbs Flour

* 1st speed only ** 1st and 2nd speed only

1 gallon of water weights 8.33 lbs.

If high gluten flour is used, reduce above dough batch size by 10 %

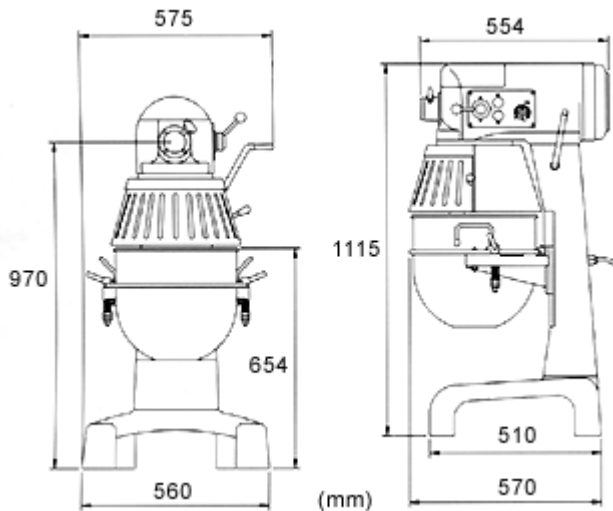

Electrical Information

Model	Voltage	Phase	Amps	Watts	Hertz	NEMA
BMPM030	110	1	16	1760	60	L5-15P

Shipping Information

Model	Net Weight	Crated Weight	Crate Dimensions (D x W x H)
BMPM030	N/A	380lbs / 173kg	28" x 24" x 51"



Authorized Dealer:



BakeMax Manufacturing, Inc.
170 Millenium Blvd, Moncton, NB, E1C 1M8
Toll Free: 1-800-565-BAKE
Telephone: 1-506-858-8990
Fax: 1-506-859-6929

Think Quality, Value, Service.....Think

BakeMax[®]

Toll Free: 1-800-565-BAKE

Web Site: www.bakemax.com

E-mail: sales@bakemax.com

Printed in Canada