



Item No. _____

120qt PLANETARY MIXER BMPM120

Features:

- Professional stand alone model.
- 100% gear driven.
- 3 HP motor offers enough power to mix stiffer dough and larger batches.
- All metal and die-cast aluminum body.
- Transmission is made of hardened alloy steel gears.
- All shafts are mounted in ball bearings.
- Automatic electronic 3 speed control.
- Planetary mixing action ensures perfect results.
- Simple hand lift for tool change and bowl removal.

Other specifications:

- 120qt stainless steel bowl.
- Easy Speed Shifting.
- # 12 Hub.
- Includes dough hook, flat beater and wire whip.
- Safety guard is standard for model BMPM080 and provides with automatic shut-off when guard is opened at any speed.
- Optional **Hydraulic Bowl Lifts** available.



BakeMax[®] Planetary Mixers provide durability, long life and excellent mixing performance. A wide range of sizes to choose from provides clients with the exact mixer for their particular needs. They are safe, easy to use and capable of a broad range of dough and food mixing applications.

Think Quality, Value, Service.....Think

BakeMax[®]

80qt PLANETARY MIXER BMPM080

Volume

External and Internal Dimensions (D x W x H)

Model	External
BMPM120	44.8" x 33.1" x 60" 114 x 86 x 152 cm

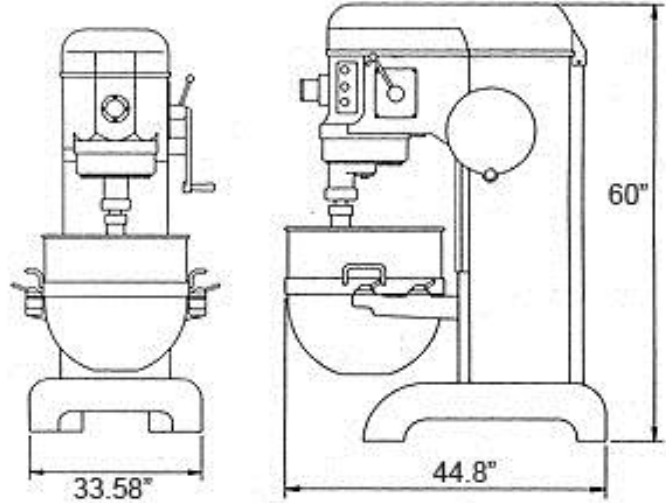
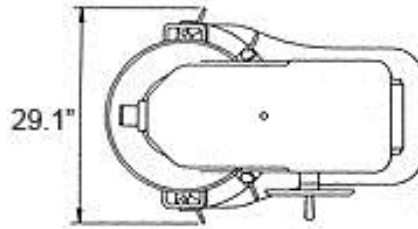

Electrical Information

Model	Voltage	Phase	HP	Hertz	NEMA
BMPM120	220	3	5	60	No Plug

Shipping Information

Model	Net Weight	Crated Weight	Crate Dimensions (D x W x H)
BMPM120		1620lbs / 784lbs	52" x 36" x 71"



Authorized Dealer:



BakeMax Manufacturing, Inc.
170 Millenium Blvd, Moncton, NB, E1C 1M8
Toll Free: 1-800-565-BAKE
Telephone: 1-506-858-8990
Fax: 1-506-859-6929

Think Quality, Value, Service.....Think

BakeMax[®]

Toll Free: 1-800-565-BAKE

Web Site: www.bakemax.com

E-mail: sales@bakemax.com

Printed in Canada